

# UTILITY REFRIGERATOR

## LOW HEIGHT REFRIGERATOR-SELF-CONTAINED-TWO SECTION



MODEL LHR-60-4D-EM  
SHOWN WITH OPTIONAL MARINE EDGE TOP

MODEL NO.	DESCRIPTION
<input type="checkbox"/> LHR-60-4D-EM	78" Wide, Four Drawers, 7 Pans Front-to-Back
<input type="checkbox"/> LHR-60T-4D-EM	78" Wide, Four Drawers, 7 Pans Front-to-Back
<input type="checkbox"/> LHR-66-4D-EM	84" Wide, Four Drawers, 8 Pans FB/SBS
<input type="checkbox"/> LHR-66T-4D-EM	84" Wide, Four Drawers, 8 Pans FB/SBS
<input type="checkbox"/> LHR-72-4D-EM	90" Wide, Four Drawers, 8 Pans Side-by-Side
<input type="checkbox"/> LHR-72T-4D-EM	90" Wide, Four Drawers, 8 Pans Side-by-Side

Model numbers with "T" accommodate 6" deep pans for extra capacity  
See nomenclature for model numbers with drawer combinations  
"FB/SBS" indicates 4 pans each front-to-back and side-by-side

### STANDARD FEATURES

- Modular design allows for side-by-side line up of cabinets
- Stainless steel front, sides and self-closing drawers
- Rugged drawer construction
- Integral one-piece stainless steel drawer pull
- Snap-in magnetic gaskets
- Coved corner stainless steel interior
- Drawers hold 12" x 20" pans or fractional pans (pans by others)
- One chrome plated wire shelf per door opening (with door option)
- Adjustable 6" heavy-duty legs or 6" casters in lieu of legs
- Compressor housing on left side (optional on right side)
- Heavy-duty, built-in security cylinder door lock
- Concealed condensate heaters around each opening
- Self-closing door hinges with stay-open feature at 120 degrees (std. door hinging is left door hinged left, center and right doors hinged right; other configurations available)
- Expansion valve refrigeration system
- Digital temperature control
- **Reinforced sub-top to support heavy restaurant equipment**
- **Specially insulated top for efficient cooling when used with cooking equipment**
- Low cabinet height places cooking equipment at ergonomically convenient level
- Hot gas condensate evaporator
- R-404a refrigerant for superior temperature recovery and pulldown
- Impact-resistant PVC breaker strip
- One 10 ft. electrical cord with 3-prong grounded plug
- **5 year compressor, 3 year parts, 1 year labor warranty**

### OPTIONS & ACCESSORIES

- Stainless steel top (specify equipment flat, or marine edge type)
- Stainless steel back \_\_\_ and/or bottom \_\_\_ (specify either or both)
- Marine secure latch
- Door in lieu of drawers (specify hinging)
- Drawer locking hasp
- Additional chrome wire shelves (specify quantity) \_\_\_\_\_
- Stainless steel wire shelves in lieu of chrome
- Temperature alarm
- 6" front locking casters in lieu of legs (no charge)
- 6" seismic legs
- Correctional facilities package
- Compressor on right side (no charge)
- Water-cooled condensing unit
- Custom modifications (please specify)



#### UTILITY REFRIGERATOR

Manufacturers of The Finest Quality Refrigeration Equipment  
Since 1931

www.utilityrefrigerator.com

PROUDLY MADE IN THE USA





# UTILITY REFRIGERATOR

## LOW HEIGHT REFRIGERATOR-SELF-CONTAINED-TWO SECTION

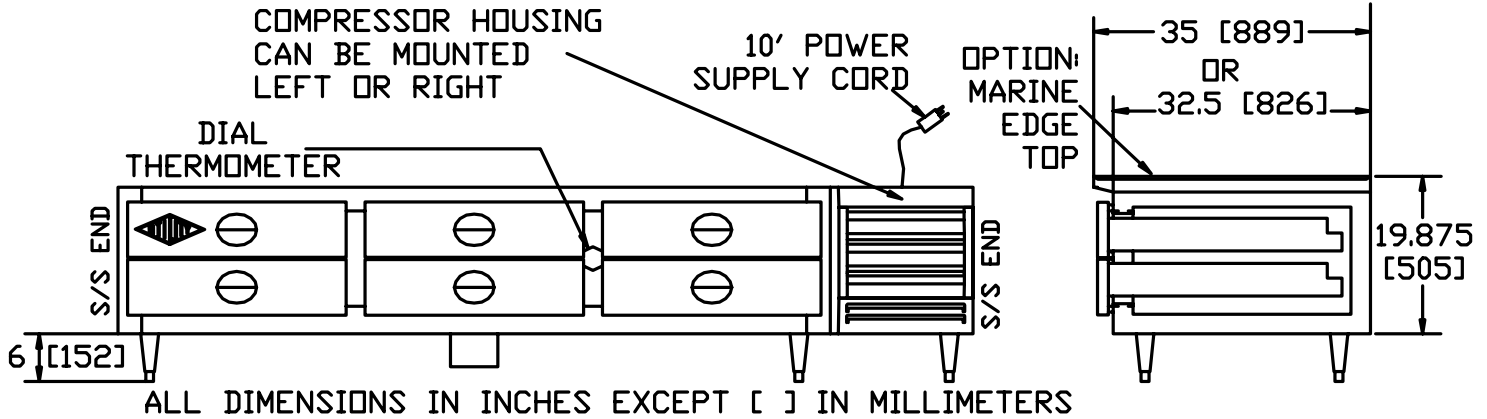

PRODUCT DATA (DATA IS FOR STD. MODELS: OPTIONS MAY CHANGE SPECIFICATIONS)	LHR-60-4D-EM	LHR-60T-4D-EM	LHR-66-4D-EM	LHR-66T-4D-EM	LHR-72-4D-EM	LHR-72T-4D-EM
Width (overall)	78"	78"	84"	84"	90"	90"
Depth (overall)	34 1/2"	34 1/2"	34 1/2"	34 1/2"	34 1/2"	34 1/2"
Height (optional stainless top adds 1")	25"	27"	25"	27"	25"	27"
Depth (overall, drawer fully extended)	55 1/2"	55 1/2"	55 1/2"	55 1/2"	55 1/2"	55 1/2"
Pan capacity, 12" x 20" pans	7	7	8	8	8	8
Voltage (dedicated circuit required)	115	115	115	115	115	115
Amperage	12.1	12.2	12.2	12.3	13.0	13.1
NEMA plug configuration	5-15 P	5-15 P	5-15 P	5-15 P	5-15 P	5-15 P
Horsepower	1/4	1/4	1/4	1/4	1/4	1/4
Ship weight (lbs.)	477	490	512	525	560	573
Ship volume (cu. ft.)	50	54	54	58	57	62
Crated dimensions (38 1/2" D)	27" H x 83 1/2" W	29" H x 83 1/2" W	27" H x 89 1/2" W	29" H x 89 1/2" W	27" H x 95 1/2" W	29" H x 95 1/2" W

### SPECIFICATIONS

**Cabinet Exterior** - Exterior sides and front are constructed of heavy gauge stainless steel. Exterior back and bottom are constructed of heavy gauge galvanized or optional stainless steel. Exterior temperature display. Square-cornered construction allows for continuous side-by-side line-up of cabinets. Cabinet is supported on heavy-duty, adjustable 6" legs. Cabinet body is 100% CFC free, foamed-in-place polyurethane insulation.

**Cabinet Interior** - All heavy gauge stainless steel construction with coved corners. Heavy-duty stainless steel shelf standards and shelf clips for superior durability and corrosion resistance. One (1) chrome plated wire shelf per door opening. Each drawer has four, 2" diameter stainless steel ball-bearing rollers which travel on 14 gauge stainless steel slides. Section openings protected by impact-resistant PVC breaker strip.

**Doors** - All stainless steel construction with magnetic snap-in gasket. Section openings have built-in energy saving condensate heaters. One piece, stamped door handle with built-in security cylinder lock. In order to prevent damage to door during installation, doors are equipped with self-closing lift-off cam hinges for easy door removal. Doors stay open at 120 degrees for easy access to interior. Insulation is 100% CFC free, foamed-in-place polyurethane. Standard door hinging is left door hinged left, center and right doors hinged right (other configurations available-please specify).

**Refrigeration** - R-404a refrigerant. Thermostatic expansion valve for superior performance and efficiency, faster temperature recovery, shorter running time and lower energy consumption. Pressure control prevents compressor burnout in case of loss of refrigerant. Easy-to-use digital temp. control enables users to adjust setpoint between 35-40 degrees F.



**UTILITY REFRIGERATOR**  
 Manufacturers of The Finest Quality Refrigeration  
 Equipment Since 1931  
 10029 Bradley Ave. Pacoima, CA 91331  
 (818) 899-8300 Fax (818) 899-8335  
 www.utilityrefrigerator.com

In line with its policy to continually improve its products, Utility Refrigerator reserves the right to change materials and specifications without notice.



UTILITY® IS PROUDLY MADE IN THE USA

LHREM2-GL