



UTILITY REFRIGERATOR

ONE SECTION SOLID DOOR REACH-IN REFRIGERATOR



MODEL R-30-SS-1S-D

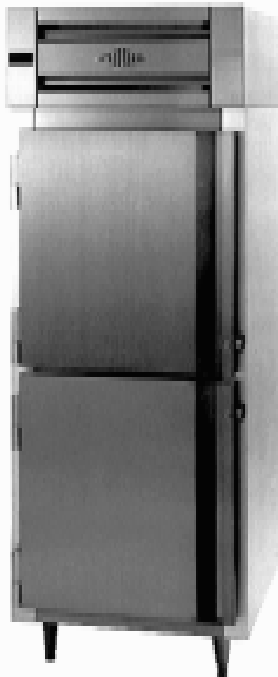

MODEL R-30-SS-2S-D
SHOWN W/ OPTIONAL HINGING
(DOORS HINGED LEFT)

**UTILITY REFRIGERATOR**

Manufacturers of The Finest Quality Refrigeration Equipment
Since 1931

www.utilityrefrigerator.com

PROUDLY MADE IN THE USA

MODEL NO.	DESCRIPTION
<input type="checkbox"/> R-25-SS-1S-D	25" Wide, S/S Exterior & Interior
<input type="checkbox"/> R-25-SA-1S-D	25" Wide, S/S Exterior, Aluminum Interior
<input type="checkbox"/> R-25-AA-1S-D	25" Wide, S/S Front, Alum. Sides & Interior
<input type="checkbox"/> R-30-SS-1S-D	30" Wide, S/S Exterior & Interior
<input type="checkbox"/> R-30-SA-1S-D	30" Wide, S/S Exterior, Aluminum Interior
<input type="checkbox"/> R-30-AA-1S-D	30" Wide, S/S Front, Alum. Sides & Interior
OPTIONS	MODEL NO. MODIFICATION
<input type="checkbox"/> Remote	Add suffix "X" to model number
<input type="checkbox"/> Half Doors	Change "1S" to "2S"
<input type="checkbox"/> Pass-Thru	Add prefix "PT" to model number
<input type="checkbox"/> Narrow Depth	Change "D" to "N"

STANDARD FEATURES

- Stainless steel front, door, rails and top-mount
- Self-closing door hinges with stay-open feature at 120 degrees (std. door hinging is door hinged right; other configurations available)
- Full-length, one-piece recessed Unigrip™ door handle
- Heavy-duty, built-in security cylinder door lock
- Automatic interior light (switch concealed in door hinge)
- Four adjustable chrome plated wire shelves per full door opening
- Stainless steel shelf clips and shelf standards
- Adjustable 6" heavy-duty legs or 6" casters in lieu of legs
- Condensate heaters around door opening
- Snap-in magnetic door gaskets
- Expansion valve refrigeration system
- Top-mounted compressor
- Digital temperature control
- R-404a refrigerant for superior temperature recovery and pulldown
- Hot gas condensate evaporator (top-mount coil units only)
- Impact-resistant PVC breaker strip
- One 10 foot electrical cord with 3-prong grounded plug
- Master power switch
- 5 year compressor, 3 year parts, 1 year labor warranty

OPTIONS & ACCESSORIES

- Stainless steel back ___ and/or bottom___ (specify either or both)
- Drawers in lieu of lower half door (requires half-door option)
- Additional chrome wire shelves (specify quantity) _____
- Stainless steel wire shelves in lieu of chrome shelves
- Tray slides "L" Type___ Universal___ "R" Type___ (specify quantity)
- Thermostat & solenoid (remote models)
- Stainless steel curb base (specify 4" or 6" high)
- Temperature alarm
- 6" front locking casters in lieu of legs (no charge)
- 6" seismic legs
- Correctional facilities package
- Available top-mounted evaporator coil (std. depth units only)
- Water-cooled condensing unit
- 5" high top-mount (remote models)
- Custom modifications (please specify)





Project _____ Item# _____

UTILITY REFRIGERATOR

ONE SECTION SOLID DOOR REACH-IN REFRIGERATOR

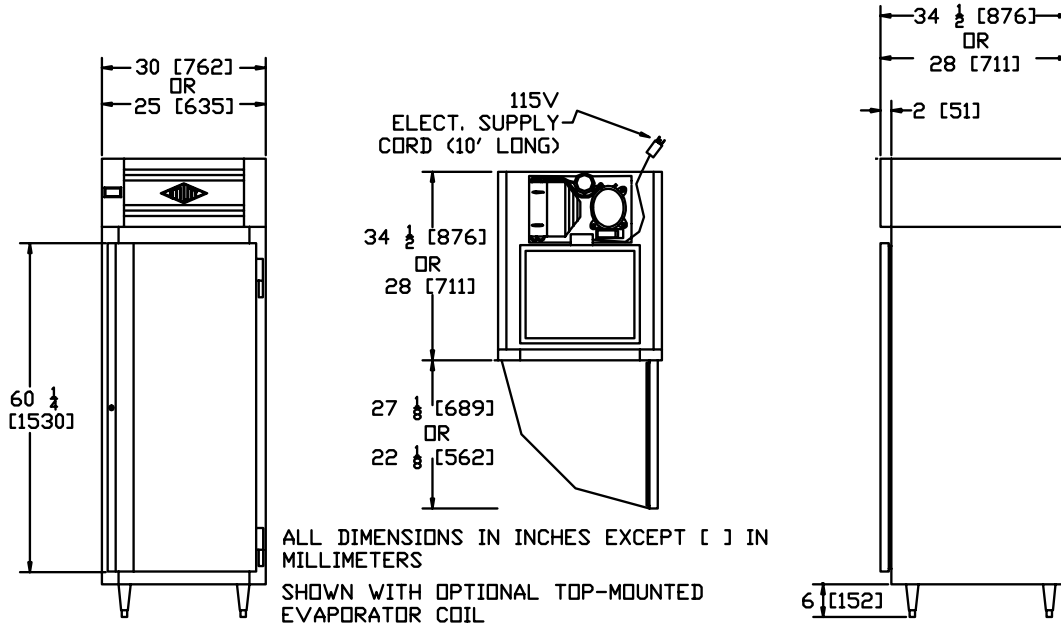

PRODUCT DATA (DATA IS FOR STD. MODELS: OPTIONS MAY CHANGE SPECIFICATIONS)	R-25 Std. Depth	R-25 Narrow Depth	R-30 Std. Depth	R-30 Narrow Depth
Width (overall)	25"	25"	30"	30"
Depth (overall)	34 1/2"	28"	34 1/2"	28"
Height (overall inc. legs)	84"	84"	84"	84"
Depth (door open 90 °)	61 5/8"	50 1/8"	61 5/8"	50 1/8"
Door opening (net width)	18 1/4"	18 1/4"	23 1/4"	23 1/4"
Door opening (net height)	57 1/4"	57 1/4"	57 1/4"	57 1/4"
Half door opening (net ht.)	26 3/4"	26 3/4"	26 3/4"	26 3/4"
Capacity (cu.ft.)	19	15	24	19
Number of shelves	4	4	4	4
Shelf area (sq. ft., including bottom)	20	16	25	20
Voltage (dedicated circuit required)	115	115	115	115
Amperage (self-contained)	9.9	9.9	10.0	10.0
Amperage (remote)	3.3	3.3	3.3	3.3
NEMA plug configuration	5-15 P	5-15 P	5-15 P	5-15 P
Horsepower (self-contained)	1/4	1/4	1/4	1/4
Ship weight (lbs.)	395	376	440	415
Ship volume, standard depth (cu.ft.)	55	46	65	54
Crated dimensions (87" H)	28 1/2" W x 38 1/2"D	28 1/2" W x 32"D	33 1/2" W x 38 1/2"D	33 1/2" W x 32"D

SPECIFICATIONS

Cabinet Exterior - Exterior sides are constructed of heavy gauge stainless steel or aluminum. Exterior back and bottom are constructed of heavy gauge galvanized or optional stainless steel. Compressor housing and louver rails are stainless steel. Exterior digital thermometer. Cabinet is supported on heavy-duty, adjustable 6" legs. Cabinet body is 100% CFC free, foamed-in-place polyurethane insulation.

Cabinet Interior - All heavy gauge stainless steel or aluminum construction with radius corners. Automatic interior light with concealed actuator. Heavy-duty stainless steel shelf standards and shelf clips for superior durability and corrosion resistance. Four (4) chrome plated wire shelves per section. Door openings protected by impact-resistant PVC breaker strip.

Doors - All welded, stainless steel construction with magnetic snap-in gasket. Door perimeters have built-in energy saving condensate heaters. Integral full-length Unigrip™ recessed door handle with heavy-duty, built-in security lock. In order to prevent damage to door during installation, doors are equipped with self-closing lift-off cam hinges for easy door removal. Doors stay open at 120 degrees for easy access to interior. Insulation is 100% CFC free foamed-in-place polyurethane. Standard door hinging is door hinged right (other configurations available; please specify).

Refrigeration - Top-mounted fully hermetic compressor with R-404a refrigerant. Thermostatic expansion valve for superior performance and efficiency, faster temperature recovery, less running time and lower energy consumption. Hot gas condensate evaporator on units equipped with top-mount coil (units with ceiling-mounted coil have electric condensate evaporator). Pressure control prevents compressor burnout in case of loss of refrigerant. Easy-to-use digital temp. control enables users to adjust setpoint between 35-40 degrees F.

In line with its policy to continually improve its products, Utility Refrigerator reserves the right to change materials and specifications without notice.



UTILITY REFRIGERATOR

Manufacturers of The Finest Quality Refrigeration Equipment Since 1931
10029 Bradley Ave. Pacoima, CA 91331
(818) 899-8300 Fax (818) 899-8335
www.utilityrefrigerator.com

UTILITY® IS PROUDLY MADE IN THE USA R25S-GL