



Project _____

Item No. _____

Model No. _____

Quantity _____

CSI No. 114000

MERCHANDISERS – 36" AND 48" WIDE



PT-R-30-SS-2SLG-2SLG-N-C
36" Wide, Pass-Thru, Narrow Depth

R-50-2SLG-N-C
(Shown with optional laminate finish)

MODEL GUIDE

Model Number	Description
<input type="checkbox"/> R-30-SS-2SLG-N-C	36" Wide, Reach-In, Narrow Depth
<input type="checkbox"/> R-30-SS-2SLG-D-C	36" Wide, Reach-In, Standard Depth
<input type="checkbox"/> PT-R-30-SS-2SLG-2SLG-N-C	36" Wide, Pass-Thru, Narrow Depth
<input type="checkbox"/> PT-R-30-SS-2SLG-2SLG-D-C	36" Wide, Pass-Thru, Standard Depth
<input type="checkbox"/> R-50-SS-2SLG-N-C	48" Wide, Reach-In, Narrow Depth
<input type="checkbox"/> R-50-SS-2SLG-D-C	48" Wide, Reach-In, Standard Depth
<input type="checkbox"/> PT-R-50-SS-2SLG-2SLG-N-C	48" Wide, Pass-Thru, Narrow Depth
<input type="checkbox"/> PT-R-50-SS-2SLG-2SLG-D-C	48" Wide, Pass-Thru, Standard Depth

STANDARD FEATURES:

Construction/Cabinet

- Exterior front and sides – heavy gauge stainless steel
- Exterior bottom – heavy gauge galvanized
- Stainless steel compressor housing
- Stainless steel top and back
- Stainless steel interior
- Heavy-duty 6" adjustable stainless steel legs
- Cabinet body is foamed-in-place minimum 2-1/2" thick polyurethane insulation
- Fully coved interior with welded radius corners for easy cleaning
- Interior LED lighting
- Three adjustable chrome plated wire shelves
- Self-closing vinyl frame sliding glass doors

Refrigeration Package

- Expansion valve refrigeration system for superior recovery and temperature pull-down
- Low Pressure control – prevents compressor burnout in case of refrigerant loss
- Bottom-mounted compressor
- R-513a, non-flammable, low GWP refrigerant for superior temperature recovery and pull-down
- Hot gas condensate evaporator quickly dissipates condensation using zero additional energy
- Receiver tank and service valves – allows reuse of refrigerant and enables rapid pull-down during times of peak demand
- Integrated sight glass – allows technicians to easily detect leaks or moisture without tools

Control Systems & Warranty Coverage

- Digital temperature control – easily adjust setpoint between 35-40°F
- Master power switch
- One 6 foot electrical cord
- Warranty: 5 year compressor, 5 year parts, 1 year labor

KEY FEATURE:

- NSF Approved for beverage AND food storage (able to merchandise non-perishable beverages such as water and soda as well as perishable food products and beverages including milk)

OPTIONS & ACCESSORIES:

- Temperature alarm
- 6" front locking casters in lieu of legs (no charge)
- 4" front locking casters in lieu of legs
- 6" seismic legs
- Beverage glides
- Glass door lock
- Laminate exterior finish (specify manufacturer and pattern)
- Flange trim for recessed installation into serving counter
- Custom vinyl wrap exterior finish

AGENCY APPROVALS:



Intertek



Intertek



MERCHANDISERS – 36" AND 48" WIDE

R-30-SS-2SLG-N-C

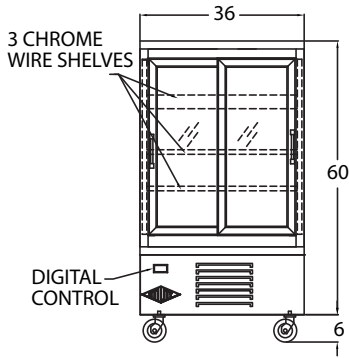

FRONT VIEW

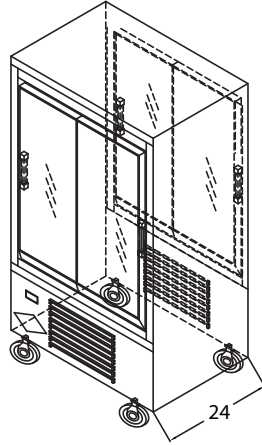

ISOMETRIC VIEW

R-50-SS-2SLG-N-C

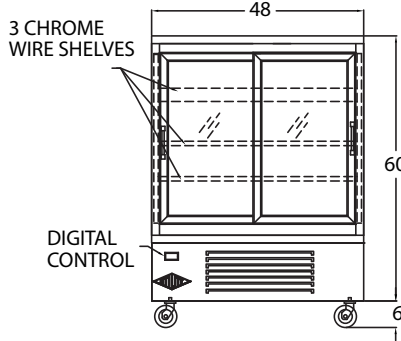

FRONT VIEW

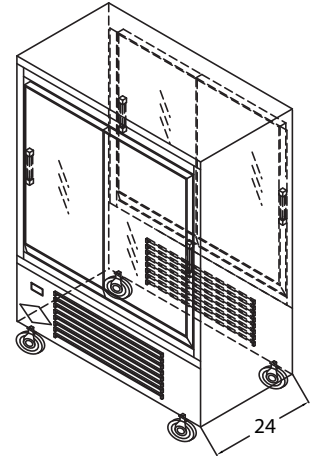

ISOMETRIC VIEW

PRODUCT DATA	R-30-SS-2SLG-D-C	R-30-SS-2SLG-N-C	R-50-SS-2SLG-D-C	R-50-SS-2SLG-N-C
	Standard Depth	Narrow Depth	Standard Depth	Narrow Depth
KEY DIMENSIONS				
Width (overall)	36.0"	36.0"	48.0"	48.0"
Depth (overall)	30.0"	24.0"	30.0"	24.0"
Depth Pass-Thru Models (overall)	30.0"	24.0"	30.0"	24.0"
Height (overall inc. legs)	66.0"	66.0"	66.0"	66.0"
CAPACITY				
Capacity (cu. ft.)	16.6	12.6	23.0	17.5
Number of Shelves	3	3	3	3
Shelf Area (sq. ft., including bottom)	20.0	15.2	28.4	21.6
ELECTRICAL				
Voltage (dedicated circuit required)	115V	115V	115V	115V
Amperage	8.7	8.7	8.7	8.7
NEMA Plug Configuration	5-15 P	5-15 P	5-15 P	5-15 P
Horsepower	1/3	1/3	1/3	1/3
SHIPPING				
Ship Weight (lbs.)	400	400	700	700
Ship Volume, Standard Depth (cu. ft.)	53.6	47.2	70.1	54.7
Crated Dimensions (72" H)	39"W x 33"D	39"W x 27"D	51"W x 33"D	51"W x 27"D
Crated Dimensions - Pass-Thru (72" H)	39"W x 33"D	39"W x 27"D	51"W x 33"D	51"W x 27"D

Data is for standard models; options may change specifications.

UTILITY REFRIGERATOR

12160 Sherman Way • North Hollywood, CA 91605

Telephone: (818) 764-6200 • Fax: (818) 764-6211

www.utilityrefrigerator.com

DUE TO CONTINUOUS PRODUCT IMPROVEMENTS, SPECIFICATIONS ARE SUBJECT TO CHANGE WITHOUT NOTICE.

©/™/® Utility Refrigerator



BIM | CAD | MOBILE



WARNING - This product can expose you to chemicals including Di(2-ethylhexyl)phthalate (DEHP), which is [are] known to the State of California to cause cancer and birth defects or other reproductive harm. For more information go to www.P65Warnings.ca.gov

UR-R2 | MU