



Project _____
 Item No. _____
 Model No. _____
 Quantity _____

CSI No. 114000

REACH-IN DUAL TEMP - TWO SECTION



RF-50-SS-2S-D
 50" Wide, S/S Exterior & Interior

MODEL GUIDE

| Model Number | Description |
|---|-----------------------------------|
| <input type="checkbox"/> RF-50-SS-2S-D | 50" Wide, S/S Exterior & Interior |
| <input type="checkbox"/> RF-60-SS-2S-D | 60" Wide, S/S Exterior & Interior |
| Options | Model Number Modification |
| <input type="checkbox"/> Remote Refrigeration | Add suffix "X" to model number |
| <input type="checkbox"/> Half Doors | Change "2S" to "4S" |
| <input type="checkbox"/> Pass-Thru | Add prefix "PT" to model number |
| <input type="checkbox"/> Narrow Depth | Change suffix "D" to "N" |
| <input type="checkbox"/> Glass Door | Change "2S" to "2G" |

STANDARD FEATURES:

Construction/Cabinet

- Exterior sides – heavy gauge stainless steel
- Exterior back and bottom – heavy gauge galvanized
- Stainless steel compressor housing
- Stainless steel front, door, rails and top-mount
- Heavy-duty 6" adjustable stainless steel legs
- Cabinet body is foamed-in-place polyurethane insulation
- Fully covered interior with welded radius corners for easy cleaning
- Interior LED lighting
- Stainless steel shelf clips and shelf standards
- Four adjustable chrome plated wire shelves per section

Doors

- Self-closing, lift off door hinges with stay-open feature at 120°
- Standard left door hinged left, right door hinged right (other configurations available)
- Full-length, one-piece recessed Unigrip™ door handle (solid door models)
- Heavy-duty, built-in security cylinder door lock (solid door models)
- Energy saving condensate heater around door opening
- Snap-in magnetic door gasket
- Impact-resistant PVC breaker strip

Refrigeration Package

- Expansion valve refrigeration system for superior recovery and temperature pulldown
- Pressure control – prevents compressor burnout in case of refrigerant loss
- Top-mounted compressor
- R-449a, low GWP refrigerant for superior temperature recovery and pulldown
- Hot gas condensate evaporator quickly dissipates condensation using zero additional energy
- Receiver tank and service valves – allows reuse of refrigerant and enables rapid pulldown during times of peak demand
- Integrated sight glass – allows technicians to easily detect leaks or moisture without tools

Control Systems & Warranty Coverage

- Dual digital temperature controls – easily adjust refrigerator setpoint between 35-40°F; freezer setpoint between -5 to +5°F
- Master power switch
- One 9 foot electrical cord
- Warranty: 5 year compressor, 5 year parts, 1 year labor

OPTIONS & ACCESSORIES:

- Stainless steel back ___ top___ bottom___ (specify all that apply)
- Drawers in lieu of lower half door (requires half-door option)
- Additional chrome wire shelves (specify quantity) _____
- Stainless steel wire shelves in lieu of chrome shelves
- Tray slides (specify quantity)
 "L"Type ___ Universal slides ___ "R"Type ___
- Digital temperature control & solenoid for remote models
- Stainless steel curb base (specify 4" or 6" high)
- Temperature alarm
- 6" front locking casters in lieu of legs (no charge)
- 4" front locking casters in lieu of legs
- 6" seismic legs
- Correctional facilities package
- Top-mounted evaporator coil (std. depth units only)
- Water-cooled condensing unit
- 5" high top-mount (remote compressor models)

AGENCY APPROVALS:



Intertek



Intertek



REACH-IN DUAL TEMP - TWO SECTION

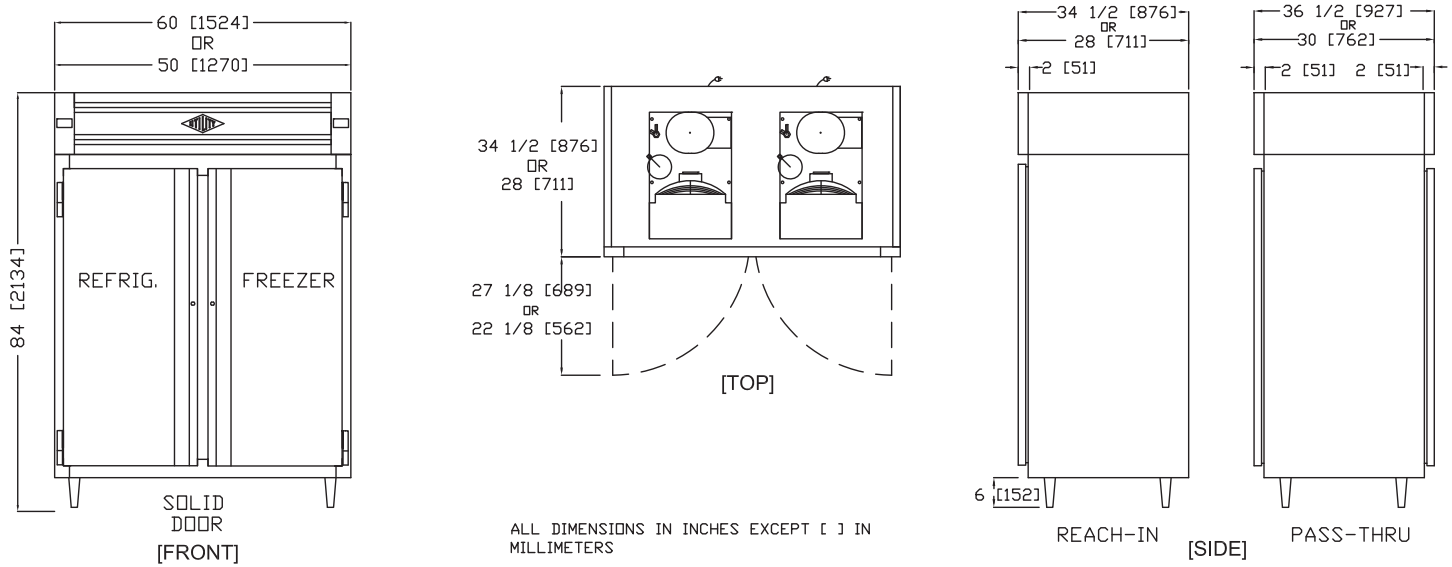

| PRODUCT DATA | RF-50 Series Standard Depth | RF-50 Series Narrow Depth | RF-60 Series Standard Depth | RF-60 Series Narrow Depth |
|--|-----------------------------|---------------------------|-----------------------------|---------------------------|
| KEY DIMENSIONS | | | | |
| Width (overall) | 50.0" | 50.0" | 60.0" | 60.0" |
| Depth (overall) | 34.5" | 28.0" | 34.5" | 28.0" |
| Depth Pass-Thru Models (overall) | 36.5" | 30.0" | 36.5" | 30.0" |
| Height (overall inc. legs) | 84.0" | 84.0" | 84.0" | 84.0" |
| Door Opening (net width) | 18.25" | 18.25" | 23.25" | 23.25" |
| Door Opening (net height) | 57.25" | 57.25" | 57.25" | 57.25" |
| Half Door Opening (net ht.) | 26.75" | 26.75" | 26.75" | 26.75" |
| CAPACITY | | | | |
| Capacity (cu.ft.) | 38 | 29 | 48 | 36 |
| Number of Shelves | 8 | 8 | 8 | 8 |
| Shelf Area (sq. ft., including bottom) | 39 | 29 | 48 | 36 |
| ELECTRICAL | | | | |
| Voltage (two dedicated circuits required) | 115 | 115 | 115 | 115 |
| Amperage (self-contained; refrigerator compartment) | 5.4 | 5.4 | 5.5 | 5.5 |
| Amperage (self-contained; freezer compartment) | 7.5 | 7.5 | 7.6 | 7.6 |
| Amperage (remote; refrigerator compartment) | 5.0 | 5.0 | 5.1 | 5.1 |
| Amperage (remote; freezer compartment) | 8.3 | 8.3 | 9.5 | 8.4 |
| BTU requirement*, remote (refrigerator compartment) | 1440 | 1395 | 1575 | 1495 |
| BTU requirement*, remote (freezer compartment) | 1850 | 1775 | 2390 | 1875 |
| NEMA Plug Config (self-contained only, refrigerator compartment) | 5-15 P | 5-15 P | 5-15 P | 5-15 P |
| NEMA Plug Config (self-contained only, freezer compartment) | 5-15 P | 5-15 P | 5-15 P | 5-15 P |
| Horsepower (self-contained; refrigerator compartment) | 1/4 | 1/4 | 1/4 | 1/4 |
| Horsepower (self-contained; freezer compartment) | 1/3 | 1/3 | 1/3 | 1/3 |
| SHIPPING | | | | |
| Ship Weight (lbs.) | 790 | 680 | 960 | 800 |
| Ship Volume, Standard Depth (cu.ft.) | 135 | 118 | 160 | 140 |
| Crated Dimensions (87" H) | 56"W x 48"D | 56"W x 42"D | 66"W x 48"D | 66"W x 42"D |

*90°F ambient, 20°F evaporator (refrigerator) or -15°F evaporator (freezer), 20' max. line length.

Data is for standard models; options may change specifications.

UTILITY REFRIGERATOR

12160 Sherman Way • North Hollywood, CA 91605

Telephone: (818) 764-6200 • Fax: (818) 764-6211

www.utilityrefrigerator.com

DUE TO CONTINUOUS PRODUCT IMPROVEMENTS, SPECIFICATIONS ARE SUBJECT TO CHANGE WITHOUT NOTICE.

©/™/® Utility Refrigerator



WARNING - This product can expose you to chemicals including Di(2-ethylhexyl)phthalate (DEHP), which is [are] known to the State of California to cause cancer and birth defects or other reproductive harm. For more information go to www.P65Warnings.ca.gov