



Project _____
 Item No. _____
 Model No. _____
 Quantity _____

CSI No. 114000

REACH-IN DUAL TEMP - ONE SECTION



RF-25-SS-2S-D
 25" Wide, S/S Exterior & Interior

MODEL GUIDE

Model Number	Description
<input type="checkbox"/> RF-25-SS-2S-D	25" Wide, S/S Exterior & Interior
<input type="checkbox"/> RF-25-SA-2S-D	25" Wide, S/S Exterior, Aluminum Interior
<input type="checkbox"/> RF-30-SS-2S-D	30" Wide, S/S Exterior & Interior
<input type="checkbox"/> RF-30-SA-2S-D	30" Wide, S/S Exterior, Aluminum Interior
Options	Model Number Modification
<input type="checkbox"/> Remote Refrigeration	Add suffix "X" to model number
<input type="checkbox"/> Pass-Thru	Add prefix "PT" to model number
<input type="checkbox"/> Narrow Depth	Change suffix "D" to "N"
<input type="checkbox"/> Glass Door	Change "1S" to "1G"

STANDARD FEATURES:

Construction/Cabinet

- Exterior sides – heavy gauge stainless steel
- Exterior back and bottom – heavy gauge galvanized
- Stainless steel compressor housing
- Stainless steel front, door, rails and top-mount
- Heavy-duty 6" adjustable stainless steel legs
- Cabinet body is foamed-in-place polyurethane insulation
- Fully covered interior with welded radius corners for easy cleaning
- Interior LED lighting
- Stainless steel shelf clips and shelf standards
- Four adjustable chrome plated wire shelves per section

Doors

- Self-closing door hinges with stay-open feature at 120°
- Standard right hinged door (other configurations available)
- Full-length, one-piece recessed Unigrip™ door handle (solid door models)
- Heavy-duty, built-in security cylinder door lock (solid door models)
- Energy saving condensate heater around door opening
- Snap-in magnetic door gasket
- Impact-resistant PVC breaker strip

Refrigeration Package

- Expansion valve refrigeration system for superior recovery and temperature pulldown
- Pressure control – prevents compressor burnout in case of refrigerant loss
- Top-mounted compressor
- R-449a, low GWP refrigerant for superior temperature recovery and pulldown
- Hot gas condensate evaporator quickly dissipates condensation using zero additional energy
- Receiver tank and service valves – allows reuse of refrigerant and enables rapid pulldown during times of peak demand
- Integrated sight glass – allows technicians to easily detect leaks or moisture without tools

Control Systems & Warranty Coverage

- Refrigerator section designed to maintain 35-40°F; Freezer section designed to maintain -5 to +5°F
- Master power switch
- One 9 foot electrical cord
- Warranty: 5 year compressor, 5 year parts, 1 year labor

OPTIONS & ACCESSORIES:

- Stainless steel back ___ top___ bottom___ (specify all that apply)
- Additional chrome wire shelves (specify quantity) _____
- Stainless steel wire shelves in lieu of chrome shelves
- Tray slides (specify quantity)
 "L"Type ___ Universal slides ___ "R"Type ___
- Digital temperature control & solenoid for remote models
- Stainless steel curb base (specify 4" or 6" high)
- Temperature alarm
- 6" front locking casters in lieu of legs (no charge)
- 4" front locking casters in lieu of legs
- 6" seismic legs
- Correctional facilities package
- Top-mounted evaporator coil (std. depth units only)
- Water-cooled condensing unit
- 5" high top-mount (remote compressor models)

AGENCY APPROVALS:



Intertek



Intertek



REACH-IN DUAL TEMP - ONE SECTION

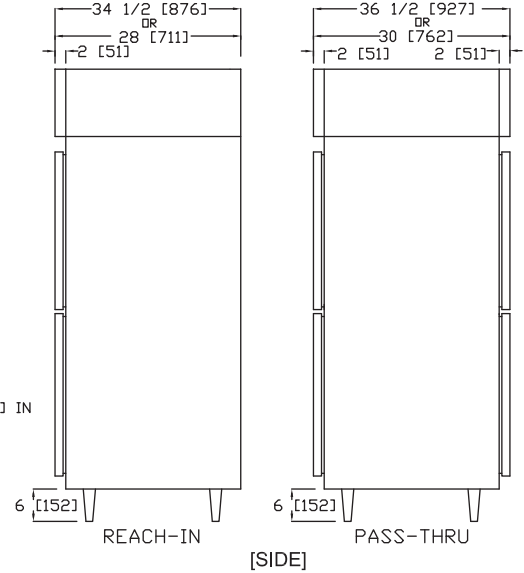
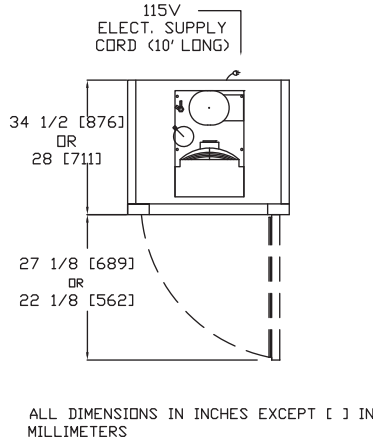
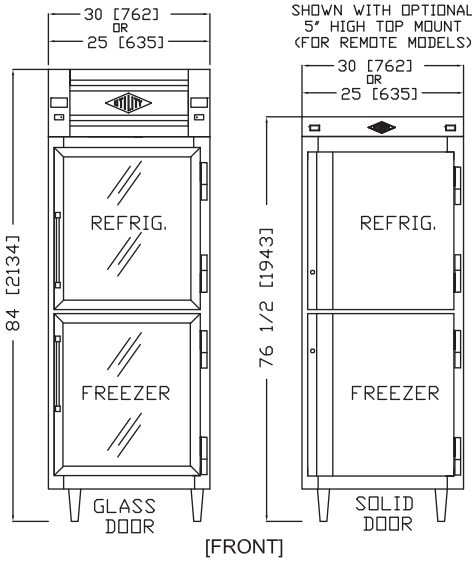

PRODUCT DATA	RF-25 Series Standard Depth	RF-25 Series Narrow Depth	RF-30 Series Standard Depth	RF-30 Series Narrow Depth
KEY DIMENSIONS				
Width (overall)	25.0"	25.0"	30.0"	30.0"
Depth (overall)	34.5"	28.0"	34.5"	28.0"
Depth Pass-Thru Models (overall)	36.5"	30.0"	36.5"	30.0"
Height (overall inc. legs)	84.0"	84.0"	84.0"	84.0"
Door Opening (net width)	18.25"	18.25"	23.25"	23.25"
Door Opening (net height)	26.75"	26.75"	26.75"	26.75"
CAPACITY				
Capacity (cu.ft.)	18	14	23	17
Number of Shelves	4	4	4	4
Shelf Area (sq. ft., including bottom)	16	12	20	15
ELECTRICAL				
Voltage (dedicated circuit required)	115	115	115	115
Amperage (self-contained)	13.3	8.6	13.3	8.6
Amperage (remote refrigeration)	9.4	9.4	9.4	9.4
BTU requirement*, remote	1850	1775	2390	1875
NEMA Plug Configuration	5-20P	5-15P	5-20P	5-15P
Horsepower (self-contained)	1/2	1/3	1/2	1/3
SHIPPING				
Ship Weight (lbs.)	525	435	625	520
Ship Volume, Standard Depth (cu.ft.)	75	66	87	76
Crated Dimensions (87" H)	31"W x 48"D	31"W x 42"D	36"W x 48"D	36"W x 42"D

*90°F ambient, 20°F evaporator (refrigerator) or -15°F evaporator (freezer), 20' max. line length.

Data is for standard models: options may change specifications.

UTILITY REFRIGERATOR

12160 Sherman Way • North Hollywood, CA 91605

Telephone: (818) 764-6200 • Fax: (818) 764-6211

www.utilityrefrigerator.com

DUE TO CONTINUOUS PRODUCT IMPROVEMENTS, SPECIFICATIONS ARE SUBJECT TO CHANGE WITHOUT NOTICE.

©/™/® Utility Refrigerator



WARNING - This product can expose you to chemicals including Di(2-ethylhexyl)phthalate (DEHP), which is [are] known to the State of California to cause cancer and birth defects or other reproductive harm. For more information go to www.P65Warnings.ca.gov

UR-RF1 | MU