



Project _____
 Item No. _____
 Model No. _____
 Quantity _____

CSI No. 114000

REACH-IN HOT FOOD CABINET - TWO SECTION



HC-60-SS-2S-D
 60" Wide, Stainless Steel Exterior and Interior (shown with optional 12" high top-mount)

STANDARD FEATURES:

Construction/Cabinet

- Independent compartments and heating systems for each section allow multiple holding temperatures, prevent intermixing of food, flavors, or odors, and save energy
- Cabinet specially designed for holding hot food (not a modified refrigerator)
- 100% hi-temp fiberglass insulation for safety, durability and longevity
- Heat resistant, non-conductive phenolic thermal breaker
- Exterior sides – heavy gauge stainless steel
- Exterior back and bottom – heavy gauge galvanized
- Stainless steel top-mount housing
- Stainless steel front, door, rails and top-mount
- Heavy-duty 6" adjustable stainless steel legs
- Fully coved interior with welded radius corners for easy cleaning
- Stainless steel shelf clips and shelf standards
- Four adjustable chrome plated wire shelves per section
- 5" high low-profile top-mount

Doors

- Self-closing door hinges with stay-open feature at 120°
- Standard left door hinged left, right door hinged right (other configurations available)
- Full-length, one-piece recessed Unigrip™ door handle (solid door models)
- Heavy-duty, built-in security cylinder door lock (solid door models)

Heating System

- Easy to set, top-mounted digital control
- Temperature setpoint memory (keeps setting when power is off)
- Main power switch
- Humidity controlling vent in top of cabinet

Control Systems & Warranty Coverage

- Digital temperature control – easily adjust setpoint between 165-175°F
- Master power switch
- One 9ft electrical cord (115V models only)
- Warranty: 5 year parts, 1 year labor

OPTIONS & ACCESSORIES:

- Stainless steel back ___ top___ bottom___ (specify all that apply)
- Additional chrome wire shelves (specify quantity) _____
- Stainless steel wire shelves in lieu of chrome shelves
- Tray slides (specify quantity)
 " L " Type ___ Universal slides ___ " R " Type ___
- Stainless steel curb base (specify 4" or 6" high)
- 6" front locking casters in lieu of legs (no charge)
- 4" front locking casters in lieu of legs
- 6" seismic legs
- Correctional facilities package
- 12" high top-mount
- One 9ft electrical cord & plug (NEMA L14-20P)

MODEL GUIDE

Model Number	Description
<input type="checkbox"/> HC-50-SS-2S-D	50" Wide, S/S Exterior and Interior
<input type="checkbox"/> HC-60-SS-2S-D	60" Wide, S/S Exterior and Interior
Options	Model Number Modification
<input type="checkbox"/> Half Doors	Change "1S" to "2S"
<input type="checkbox"/> Pass-Thru	Add prefix "PT" to model number
<input type="checkbox"/> Narrow Depth	Change suffix "D" to "N"
<input type="checkbox"/> Glass Door	Change "S" to "G"

AGENCY APPROVALS:



Intertek



Intertek



REACH-IN HOT FOOD CABINET - TWO SECTION

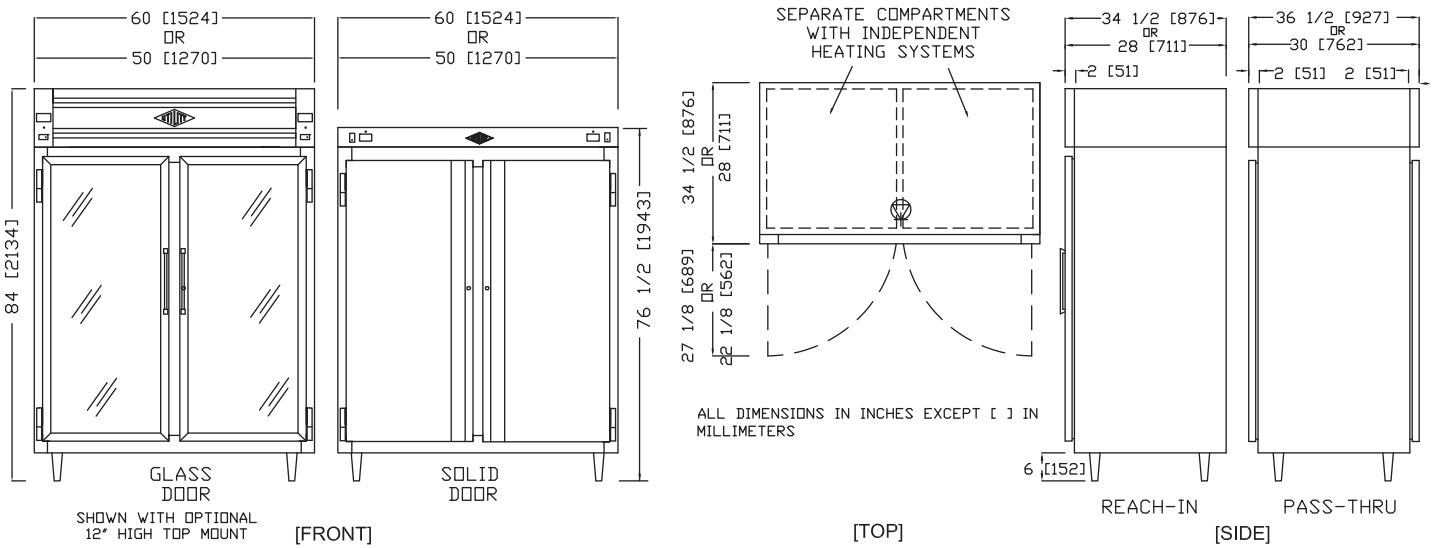

PRODUCT DATA	HC-50 Series Standard Depth	HC-50 Series Narrow Depth	HC-60 Series Standard Depth	HC-60 Series Narrow Depth
KEY DIMENSIONS				
Width (overall)	50.0"	50.0"	60.0"	60.0"
Depth (overall)	34.5"	28.0"	34.5"	28.0"
Depth Pass-Thru Models (overall)	36.5"	30.0"	36.5"	30.0"
Height, with low profile top mount (overall inc. legs)	76.5"	76.5"	76.5"	76.5"
Height, with full height top mount (overall inc. legs)	84.0"	84.0"	84.0"	84.0"
Door Opening (net width)	18.25"	18.25"	23.25"	23.25"
Door Opening (net height)	57.25"	57.25"	57.25"	57.25"
Half Door Opening (net ht.)	26.75"	26.75"	26.75"	26.75"
CAPACITY				
Capacity (cu.ft.)	38	29	48	36
Number of Shelves	8	8	8	8
Shelf Area (sq. ft., including bottom)	39	29	48	36
ELECTRICAL				
Voltage (dedicated circuit required)	208/230	208/230	208/230	208/230
Amperage (208/230V)	14.4 / 13.0	14.4 / 13.0	14.4 / 13.0	14.4 / 13.0
NEMA Plug Configuration	NO CORD & PLUG	NO CORD & PLUG	NO CORD & PLUG	NO CORD & PLUG
Wattage	3000	3000	3000	3000
SHIPPING				
Ship Weight (lbs.)	590	480	760	600
Ship Volume, Standard Depth (cu.ft.)	135	118	160	140
Crated Dimensions (87" H)	56"W x 48"D	56"W x 42"D	66"W x 48"D	66"W x 42"D

Data is for standard models: options may change specifications.

UTILITY REFRIGERATOR

12160 Sherman Way • North Hollywood, CA 91605

Telephone: (818) 764-6200 • Fax: (818) 764-6211

www.utilityrefrigerator.com

DUE TO CONTINUOUS PRODUCT IMPROVEMENTS, SPECIFICATIONS ARE SUBJECT TO CHANGE WITHOUT NOTICE.

©/™/® Utility Refrigerator



WARNING - This product can expose you to chemicals including Di(2-ethylhexyl)phthalate (DEHP), which is [are] known to the State of California to cause cancer and birth defects or other reproductive harm. For more information go to www.P65Warnings.ca.gov

UR-HC2 | MU