



Project \_\_\_\_\_  
 Item No. \_\_\_\_\_  
 Model No. \_\_\_\_\_  
 Quantity \_\_\_\_\_

CSI No. 114000

# REACH-IN HOT FOOD CABINET - ONE SECTION



HC-30-SS-2S-D  
 30" Wide, Stainless Steel Exterior and Interior, half height doors (shown with optional 12" high top-mount)

## STANDARD FEATURES:

### Construction/Cabinet

- Cabinet specially designed for holding hot food (not a modified refrigerator)
- 100% hi-temp fiberglass insulation for safety, durability and longevity
- Heat resistant, non-conductive phenolic thermal breaker
- Exterior sides – heavy gauge stainless steel
- Exterior back and bottom – heavy gauge galvanized
- Stainless steel top-mount housing
- Stainless steel front, door, rails and top-mount
- Heavy-duty 6" adjustable stainless steel legs
- Fully coved interior with welded radius corners for easy cleaning
- Stainless steel shelf clips and shelf standards
- Four adjustable chrome plated wire shelves per section
- 5" high low-profile top-mount

### Doors

- Self-closing door hinges with stay-open feature at 120°
- Standard right hinged door (other configurations available)
- Full-length, one-piece recessed Unigrip™ door handle (solid door models)
- Heavy-duty, built-in security cylinder door lock (solid door models)

### Heating System

- Easy to set, top-mounted digital control
- Temperature setpoint memory (keeps setting when power is off)
- Main power switch
- Humidity controlling vent in top of cabinet

### Control Systems & Warranty Coverage

- Digital temperature control – easily adjust setpoint between 165-175°F
- Master power switch
- One 9 foot electrical cord
- Warranty: 5 year parts, 1 year labor

## OPTIONS & ACCESSORIES:

- Stainless steel back \_\_\_ top\_\_\_ bottom\_\_\_ (specify all that apply)
- Additional chrome wire shelves (specify quantity) \_\_\_\_\_
- Stainless steel wire shelves in lieu of chrome shelves
- Tray slides (specify quantity)  
     "L"Type \_\_\_ Universal slides \_\_\_ "R"Type \_\_\_
- Stainless steel curb base (specify 4" or 6" high)
- 6" front locking casters in lieu of legs (no charge)
- 4" front locking casters in lieu of legs
- 6" seismic legs
- Correctional facilities package
- 12" high top-mount

## MODEL GUIDE

Model Number	Description
<input type="checkbox"/> HC-25-SS-1S-D	25" Wide, S/S Exterior and Interior
<input type="checkbox"/> HC-30-SS-1S-D	30" Wide, S/S Exterior and Interior
Options	Model Number Modification
<input type="checkbox"/> Half Doors	Change "1S" to "2S"
<input type="checkbox"/> Pass-Thru	Add prefix "PT" to model number
<input type="checkbox"/> Narrow Depth	Change suffix "D" to "N"
<input type="checkbox"/> Glass Door	Change "S" to "G"

## AGENCY APPROVALS:



Intertek



Intertek



# REACH-IN HOT FOOD CABINET - ONE SECTION

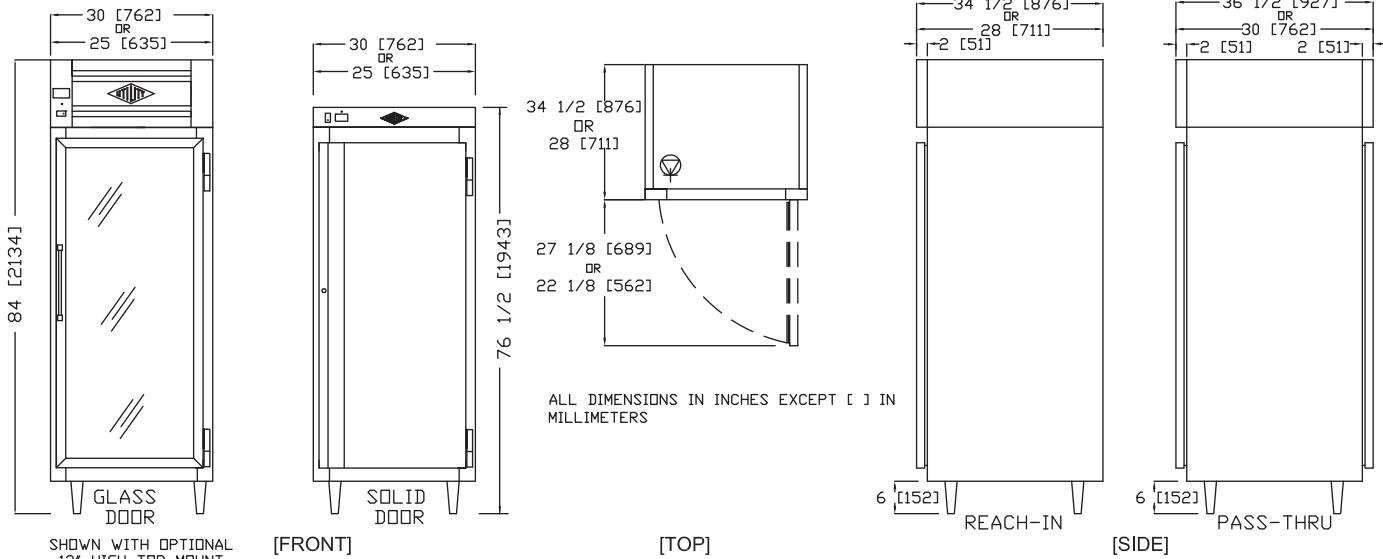

PRODUCT DATA	HC-25 Series Standard Depth	HC-25 Series Narrow Depth	HC-30 Series Standard Depth	HC-30 Series Narrow Depth
<b>KEY DIMENSIONS</b>				
Width (overall)	25.0"	25.0"	30.0"	30.0"
Depth (overall)	34.5"	28.0"	34.5"	28.0"
Depth Pass-Thru Models (overall)	36.5"	30.0"	36.5"	30.0"
Height, with low profile top mount (overall inc. legs)	76.5"	76.5"	76.5"	76.5"
Height, with full height top mount (overall inc. legs)	84.0"	84.0"	84.0"	84.0"
Door Opening (net width)	18.25"	18.25"	23.25"	23.25"
Door Opening (net height)	57.25"	57.25"	57.25"	57.25"
Half Door Opening (net ht.)	26.75"	26.75"	26.75"	26.75"
<b>CAPACITY</b>				
Capacity (cu.ft.)	19	15	24	18
Number of Shelves	4	4	4	4
Shelf Area (sq. ft., including bottom)	16	12	20	15
<b>ELECTRICAL</b>				
Voltage (dedicated circuit required)	115 or 208/230	115 or 208/230	115 or 208/230	115 or 208/230
Amperage (115V)	13.0	13.0	13.0	13.0
Amperage (208/230V)	7.2 / 6.5	7.2 / 6.5	7.2 / 6.5	7.2 / 6.5
NEMA Plug Configuration (115V only)*	5-15 P	5-15 P	5-15 P	5-15 P
Wattage	1500	1500	1500	1500
<b>SHIPPING</b>				
Ship Weight (lbs.)	450	360	550	445
Ship Volume, Standard Depth (cu.ft.)	75	66	87	76
Crated Dimensions (87" H)	31"W x 48"D	31"W x 42"D	36"W x 48"D	36"W x 42"D

\*208/230V models hardwired

Data is for standard models: options may change specifications.

## UTILITY REFRIGERATOR

12160 Sherman Way • North Hollywood, CA 91605

Telephone: (818) 764-6200 • Fax: (818) 764-6211

[www.utilityrefrigerator.com](http://www.utilityrefrigerator.com)

*DUE TO CONTINUOUS PRODUCT IMPROVEMENTS, SPECIFICATIONS ARE SUBJECT TO CHANGE WITHOUT NOTICE.*

©/™/® Utility Refrigerator



WARNING - This product can expose you to chemicals including Di(2-ethylhexyl)phthalate (DEHP), which is [are] known to the State of California to cause cancer and birth defects or other reproductive harm. For more information go to [www.P65Warnings.ca.gov](http://www.P65Warnings.ca.gov)

UR-HC1 | MU