



Project _____
 Item No. _____
 Model No. _____
 Quantity _____

CSI No. 114000

COUNTER HEIGHT HOT FOOD CABINET - TWO SECTION



CHHC-60-2S-D
 66" Wide, S/S Exterior and Interior

MODEL GUIDE

Model Number	Description
<input type="checkbox"/> CHHC-50-2S-D	56" Wide, S/S Exterior and Interior
<input type="checkbox"/> CHHC-60-2S-D	66" Wide, S/S Exterior and Interior
Options	Model Number Modification
<input type="checkbox"/> Pass-Thru	Add prefix "PT" to model number
<input type="checkbox"/> Narrow Depth	Change suffix "D" to "N"
<input type="checkbox"/> Glass Door	Change "2S" to "2G"

STANDARD FEATURES:

Construction/Cabinet

- Cabinet specially designed for holding hot food (not a modified refrigerator)
- 100% hi-temp fiberglass insulation for safety, durability and longevity
- Heat resistant, non-conductive phenolic thermal breaker
- Exterior front and sides – heavy gauge stainless steel
- Exterior back and bottom – heavy gauge galvanized
- Stainless steel front, door, and control housing
- Heavy-duty 6" adjustable stainless steel legs
- Fully coved interior with welded radius corners for easy cleaning
- Stainless steel shelf clips and shelf standards
- One adjustable chrome plated wire shelf per section

Doors

- Self-closing, lift off door hinges with stay-open feature at 120°
- Standard left door hinged left, right door hinged right (other configurations available)
- Welded stainless steel door handle

Heating System

- Easy to set, front-mounted digital control
- Temperature setpoint memory (keeps setting when power is off)
- Main power switch
- Side mounted humidity controlling vent

Control Systems & Warranty Coverage

- Digital temperature control – easily adjust setpoint between 165-175°F
- Master power switch
- One 9 foot electrical cord
- Warranty: 5 year parts, 1 year labor

OPTIONS & ACCESSORIES:

- Stainless steel top (specify flat or marine edge type)
- Stainless steel back ___ bottom___ (specify either or both)
- Additional chrome wire shelves (specify quantity) _____
- Stainless steel wire shelf in lieu of chrome shelf
- Tray slides (specify quantity)
 "L"Type ___ Universal slides ___ "R"Type ___
- Stainless steel curb base (specify 4" or 6" high)
- 6" front locking casters in lieu of legs (no charge)
- 6" seismic legs
- 5" front locking casters
- 4" front locking casters
- ADA Height – stainless steel sub top changes overall height to 31.5"
 (requires 4" high casters)
- 2 drawers in lieu of door (CHHC-60 standard depth model only)
- Correctional facilities package

AGENCY APPROVALS:



Intertek



Intertek



COUNTER HEIGHT HOT FOOD CABINET - TWO SECTION

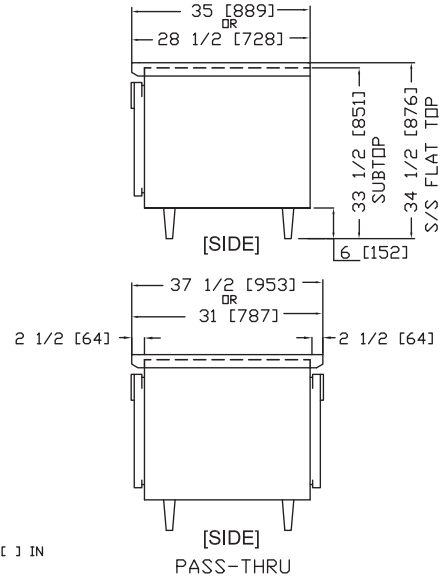
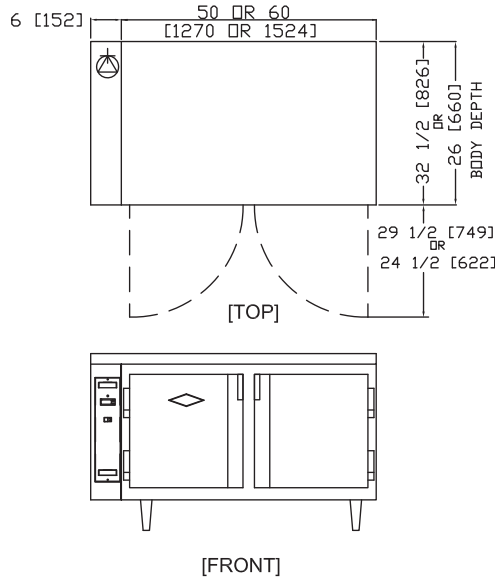

ALL DIMENSIONS IN INCHES EXCEPT [] IN MILLIMETERS

PRODUCT DATA	CHHC-50 Standard Depth	CHHC-50 Narrow Depth	CHHC-60 Standard Depth	CHHC-60 Narrow Depth
KEY DIMENSIONS				
Width (overall)	56.0"	56.0"	66.0"	66.0"
Depth (overall)	34.5"	28.0"	34.5"	28.0"
Depth Pass-Thru Models (overall)	36.5"	30.0"	36.5"	30.0"
Height (overall inc. legs; with subtop)	33.5"	33.5"	33.5"	33.5"
Height (overall inc. legs; w/ optional s/s finished top)	34.5"	34.5"	34.5"	34.5"
CAPACITY				
Capacity (cu.ft.)	14	11	18	13
ELECTRICAL				
Voltage (dedicated circuit required)	115 or 208/230	115 or 208/230	115 or 208/230	115 or 208/230
Amperage (115V)	6.1	6.1	6.1	6.1
Amperage (208/230V)	3.4	3.4	3.4	3.4
NEMA Plug Configuration*	5-15P	5-15P	5-15P	5-15P
Wattage	700	700	700	700
SHIPPING				
Ship Weight (lbs.)	320	300	400	380
Ship Volume (cu.ft.)	67	59	78	68
Crated Dimensions (39" H)	62"W x 48"D	62"W x 42"D	72"W x 48"D	72"W x 42"D

*115V models only; 208/230V models hardwired

Data is for standard models: options may change specifications.

UTILITY REFRIGERATOR

12160 Sherman Way • North Hollywood, CA 91605

Telephone: (818) 764-6200 • Fax: (818) 764-6211

www.utilityrefrigerator.com

DUE TO CONTINUOUS PRODUCT IMPROVEMENTS, SPECIFICATIONS ARE SUBJECT TO CHANGE WITHOUT NOTICE.

©/™/® Utility Refrigerator



WARNING - This product can expose you to chemicals including Di(2-ethylhexyl)phthalate (DEHP), which is [are] known to the State of California to cause cancer and birth defects or other reproductive harm. For more information go to www.P65Warnings.ca.gov

UR-CHHC2